

MEMBRANE FILTERS

Introduction	2
Properties of Membrane Filters	3
Mixed Cellulose Esters (MCE)	4
Cellulose Acetate	7
Pure Nitrocellulose for Blotting and Hybridization	8
Hydrophobic PTFE	9
Hydrophobic PTFE with Supported PP Net	10
Hydrophilic PTFE	11
Coated Cellulose Acetate	12
Polycarbonate	13
Prefilters for Membrane Filters	14
Polyester Mesh Separators	14
Disposable Syringe Filter Units	15

Introduction

Membrane filters or “membranes” are microporous plastic films with specific pore size ratings. Also known as screen, sieve or microporous filters, membranes retain particles or microorganisms larger than their pore size primarily by surface capture. Some particles smaller than the stated pore size may be retained by other mechanisms.

Advantec membranes are produced by three different processes. Mixed Cellulose Esters and Cellulose Acetate, are reverse phase solvent cast membranes, where controlled evaporation or removal of the complex solvent system forms the porous structure. Both hydrophilic and hydrophobic PTFE are made by a patented process where the membranes are stretched biaxially to form the porous structure. Polycarbonate membranes are track etched.

Performance Characteristics of Advantec Membranes

- **Strong:** Advantec membranes are monitored for both burst (longitudinal) and tensile (lateral) strength.
- **Chemically and biologically clean:** As part of a comprehensive quality program, only high purity reagents and raw materials are used to produce Advantec membranes. Once cast, the membranes are handled in a class 1000 clean room to minimize ambient contamination. While some membranes require a small amount (0.1–3 weight %) of an aqueous wetting agent, Cellulose acetate has the lowest aqueous extractables (0.1 weight %). All Advantec membranes are Triton-free.
- **Thin membranes with high porosity:** Uniformly thin membranes (typically 150 μm) with high porosity (about 80%) provide high gas and liquid flow per unit area. High porosity also provides high surface area for adsorption or binding
- **Thermostable:** All Advantec membranes can be sterilized by autoclaving. Operating temperatures of up to 180°C can be achieved depending upon the membrane polymer (see individual membrane specifications for details). Advantec membranes exhibit minimal shrinkage at elevated temperatures

Quick Guide to Selecting Membrane Filters

- **Determine** what liquid or gas will be filtered
- **Check** which membranes are chemically compatible (following and appendix)
- **Determine** the maximum pore size required to achieve the results you want
- **Check** the membrane specifications for any unusual process conditions that might otherwise limit your choice of membrane (e.g. temperature)

For more detailed information on how to design a filtration system see the appendix, page 110.

Mixed Cellulose Esters (MCE)

- **Composition:** Mixed cellulose esters including cellulose nitrate and cellulose acetate, also known as nitrocellulose
- **High porosity** provides superior flow rates
- **High protein binding** can be blocked by pretreatment or utilized in applications
- **High purity:** Triton-free
- **Autoclavable:** Withstands autoclaving temperatures up to 130°C without adversely affecting bubble point, flow rate or microbiological recovery
- **Rapid wetting time:** < 3 seconds to wet a 47 mm diameter disc with aqueous 1% methylene blue

APPLICATIONS

- Standard membranes for many laboratory applications including filter sterilizing biological fluids, microbiology, contamination analysis and air monitoring
- Can be transparentized to view collected particles
 - using compatible liquid (immersion oil, toluene),
- OR
 - select Opticlear membranes for the “hot block” acetone vapor method
- Gridded filters available for quantifying microbial growth
- Available non-sterile or sterilized by ethylene oxide (EtO)

SPECIFICATIONS FOR MIXED CELLULOSE ESTERS (MCE), CODE A

Pore Size (µm)	Color	Surface	Bubble Point* ¹		Flow Rate* ²		Porosity* ³ (%)	Thickness (µm)
			MPa	psi	Water (mL/min/cm ²)	Air (L/min/cm ²)		
0.10	White	Plain	≥0.24	≥35.3	2.7	0.67	65	110
0.20	White	Plain	≥0.37	≥54.5	17.5	2.4	73	133
0.30	White	Plain	≥0.28	≥41.2	30	3.7	75	140
0.45	White	Plain	≥0.24	≥35.0	45	5.0	78	145
0.45	White	Grid	≥0.16	≥24.2	80	8.0	79	142
0.65	White	Plain	≥0.14	≥21.3	120	11.2	79	150
0.80	White	Plain	≥0.11	≥16.4	165	15.0	80	150
1.00	White	Plain	≥0.096	≥13.9	220	20.4	80	150
3.00	White	Plain	≥0.070	≥10.2	300	28.3	81	155
5.00	White	Plain	≥0.058	≥8.5	400	40.9	81	160
0.45	Black	Grid	≥0.22	≥32.7	50	5.0	78	135
0.80	Black	Grid	≥0.10	≥14.9	170	15	80	145
0.45	Green	Grid	≥0.22	≥32.7	50	5.0	78	135
0.80	Green	Grid	≥0.10	≥14.9	170	15	80	145

- Refractive index = 1.50
- Maximum operating temperature = 130°C
- Ash content 2 ~ 5 µg/cm²

Definitions:

*1. Bubble point is the minimum pressure required to force air through a membrane which has been prewet with water (0.1 µm membranes prewet with isopropylalcohol)

*2. Flow Rate indicates initial flow rate at 10 psi using a KGS 47 filter holder

Water: using water prefiltered to 0.1 µm pore size

Air: using 25°C air at 10 psi

*3. Porosity refers to the percent open area

Metal Content of White Plain MCE Membrane Filters (ppm)

Al	<2.0	K	6.0	Ni	<5.0
Ca	140.0	Li	<1.0	Pb	<1.0
Cd	<0.5	Mg	10.0	Si	<20.0
Cr	8.0	Mn	<0.5	Sn	<5.0
Cu	<1.0	Mo	<1.0	Ti	<1.0
Fe	<5.0	Na	10.0	Zn	<1.0

ORDERING INFORMATION: MIXED CELLULOSE ESTERS – NON-STERILE**Plain White, package of 100 discs**

Pore Size (μm)	Diameter			
	13 mm	25 mm	37mm	47 mm
0.10	A010A013A	A010A025A	A010A037A	A010A047A
0.20	A020A013A	A020A025A	A020A037A	A020A047A
0.30	A030A013A	A030A025A	A030A037A	A030A047A
0.45	A045A013A	A045A025A	A045A037A	A045A047A
0.65	A065A013A	A065A025A	A065A037A	A065A047A
0.80	A080A013A	A080A025A	A080A037A	A080A047A
1.00	A100A013A	A100A025A	A100A037A	A100A047A
3.00	A300A013A	A300A025A	A300A037A	A300A047A
5.00	A500A013A	A500A025A	A500A037A	A500A047A

Plain White, package of 25 discs

Pore Size (μm)	Diameter		
	90 mm	142 mm	293 mm
0.10	A010A090C	A010A142C	A010A293C
0.20	A020A090C	A020A142C	A020A293C
0.30	A030A090C	A030A142C	A030A293C
0.45	A045A090C	A045A142C	A045A293C
0.65	A065A090C	A065A142C	A065A293C
0.80	A080A090C	A080A142C	A080A293C
1.00	A100A090C	A100A142C	A100A293C
3.00	A300A090C	A300A142C	A300A293C
5.00	A500A090C	A500A142C	A500A293C

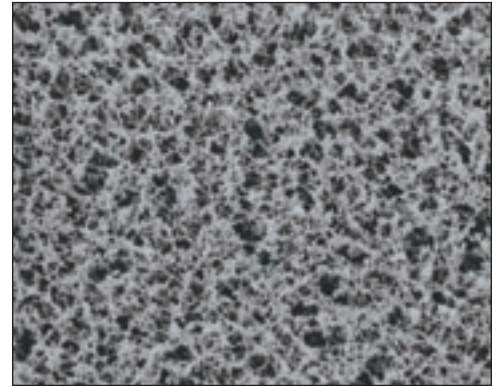

Mixed Cellulose Esters

ORDERING INFORMATION (CONTINUED): MIXED CELLULOSE ESTERS – NON-STERILE**Gridded White, package of 100 discs**

Pore Size (μm)	Diameter			
	13 mm	25 mm	37 mm	47 mm
0.45	A045B013A	A045B025A	A045B037A	A045B047A
0.80	A080B013A	A080B025A	A080B037A	A080B047A

0.8 μm MF has green grid lines on white background, 0.45 μm has black grid lines.

Sheets, Gridded White

Pore Size (μm)	Qty/pkg	Size
		300 mm x 300 mm
0.45	25	A045B304C

Hydrophobic Edge, 47 mm discs, package of 100 discs

Pore Size (μm)	Surface	
	Plain	Grid
0.20	A020J047A	A020K047A
0.45	A045J047A	A045K047A

Opticlear, package of 100 discs

Pore Size (μm)	Surface	Diameter		
		25 mm	37 mm	47 mm
0.80	Plain	A080X025A	A080X037A	A080X047A
	Grid	A080X025B	A080X037B	A080X047B

Black, package of 100 discs

Pore Size (μm)	Surface	Diameter			
		13 mm	25 mm	37 mm	47 mm
0.45	Plain	A045N013A	A045N025A	A045N037A	A045N047A
0.45	Grid	A045P013A	A045P025A	A045P037A	A045P047A
0.80	Plain	A080N013A	A080N025A	-	A080N047A
0.80	Grid	A080P013A	A080P025A	-	A080P047A

Green, package of 100 discs

Pore Size (μm)	Surface	Diameter		
		13 mm	25 mm	47 mm
0.45	Plain	A045U013A	A045U025A	A045U047A
0.45	Grid	A045V013A	A045V025A	A045V047A
0.80	Grid	-	-	A080V047A

Additional sizes available by special order.

Also available in:

- Sterile packaging for microbiology.
- Disposable syringe units.

For Pure Nitrocellulose for Blotting, see page 8.



MCE membrane filters

Cellulose Acetate

- **Composition:** Mixture of cellulose triacetate and diacetate
- **Characteristics:** Low static charge and high strength
- **Autoclavable:** Withstands autoclaving temperatures up to 130°C without adversely affecting bubble point, flow rate or microbiological recovery
- **Clean:** Lowest aqueous extractables (0.1 wt%) of all Advantec membranes
- Relative to MCE (Mixed Cellulose Esters, Nitrocellulose):
 - improved solvent resistance to low molecular weight alcohols
 - better heat resistance
 - lower protein binding

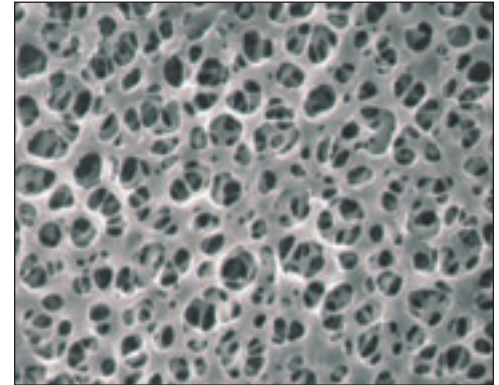

Cellulose Acetate

APPLICATIONS

- Enhanced recovery of fastidious gram positive organisms
- Filtration of enzyme solutions
- Diagnostic cytology
- Receptor binding studies

Note: Should not be prewet prior to loading into a holder and autoclaving.

SPECIFICATIONS: WHITE PLAIN CELLULOSE ACETATE, CODE C

Pore Size (µm)	Bubble Point ^{*1}		Flow Rate ^{*2}		Porosity ^{*3} (%)	Thickness (µm)
	MPa	psi	Water (mL/min/cm ²)	Air (L/min/cm ²)		
0.20	≥0.25	≥37.1	16	2	66	125
0.45	≥0.17	≥25.9	35	4	68	125
0.80	≥0.068	≥10.0	160	14	72	125
3.00	≥0.034	≥5.0	500	54	78	135

- Wetting time: <3 seconds to wet a 47 mm diameter disc with aqueous 1% methylene blue
- Refractive index = 1.47
- Maximum operating temperature = 180°C
- Ash content 1.5–3.5 µg/cm²

Definitions:

- *1. Bubble point is the minimum pressure required to force air through a membrane which has been prewet with water
- *2. Flow Rate indicates initial flow rate at 10 psi using a KGS 47 filter holder
Water: using water prefiltered to 0.1 µm pore size
Air: using 25°C air at 10 psi
- *3. Porosity refers to the percent open area

Metal Content of White Plain Cellulose Acetate Membrane Filters (ppm)

Al	<5.0	K	2.0	Ni	<0.5
Ca	36.4	Li	<0.5	Pb	<0.5
Cd	<0.1	Mg	1.9	Si	7.8
Cr	2.2	Mn	<0.5	Sn	<0.5
Cu	1.2	Mo	<0.5	Ti	<5.0
Fe	1.6	Na	5.9	Zn	0.6

ORDERING INFORMATION: CELLULOSE ACETATE – NON-STERILE

Plain White, package of 100 discs

Pore Size (µm)	Diameter			
	13 mm	25 mm	37mm	47 mm
0.20	C020A013A	C020A025A	C020A037A	C020A047A
0.45	C045A013A	C045A025A	C045A037A	C045A047A
0.80	C080A013A	C080A025A	C080A037A	C080A047A
3.00	C300A013A	C300A025A	C300A037A	C300A047A

Plain White, package of 25 discs

Pore Size (µm)	Diameter		
	90 mm	142 mm	293 mm
0.20	C020A090C	C020A142C	C020A293C
0.45	C045A090C	C045A142C	C045A293C
0.80	C080A090C	C080A142C	C080A293C
3.00	C300A090C	C300A142C	C300A293C

Rolls, Plain White, 330 mm x 3 m

Pore Size (µm)	Roll
0.20	C020A330R
0.45	C045A330R
0.80	C080A330R

Also available in:

- Cartridge format (TCR)
- Disposable syringe filter units

Pure Nitrocellulose for Blotting and Hybridization

- **Pure esters of nitrocellulose**, free of acetate and other esters
- **Maximal protein/nucleic acid binding**, up to 80-100 $\mu\text{g}/\text{cm}^2$
- **Low background**
- **Two pore sizes** available: 0.45 μm is suitable for most blotting applications, 0.20 μm sizes for lower molecular weights

ORDERING INFORMATION: NITROCELLULOSE

	Quantity per package	0.20 μm	0.45 μm
Sheets (Dimensions in mm)			
220 x 220	10	-	S045A224D
300 x 300	10	S020A304D	S045A304D
Rolls			
330 mm x 3 m	1	-	S045A330R
Discs (Diameter in mm)			
82	25	-	S045A082C

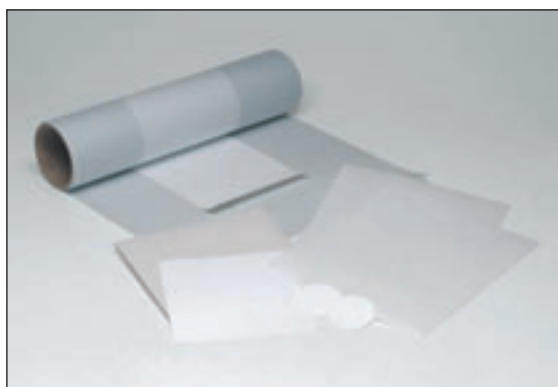

Pure Nitrocellulose and Blotting Paper.

Blotting/Chromatography Paper

APPLICATIONS

- Chromatography
- Electrophoresis and blotting
- Separation of heavily loaded solutes

SPECIFICATIONS AND CONVERSION GUIDE

Grade	Weight (g/m ²)	Thickness (mm)	Absorption Speed* ¹ (cm)	Wet Strength* ² (kPa)	Ash (%)	Whatman equivalent
No. 50	140	0.25	6.0	8	0.1	20 Chr
No. 51A	87	0.18	7.5	7	0.01	4 Chr
No. 51B	87	0.17	7.0	5	0.06	1 Chr
No. 514A	185	0.32	7.5	8	0.06	3MM Chr
No. 526	325	0.70	11	29	0.1	17 Chr

*1. Absorption speed is the distance in cm that water will travel in an upright strip of filter paper in ten (10) minutes at 20°C.

*2. Wet strength is measured by Mullen Burst Strength tester after soaking the sample with water in accordance with JIS P8112.

SOUTHERN BLOTTING

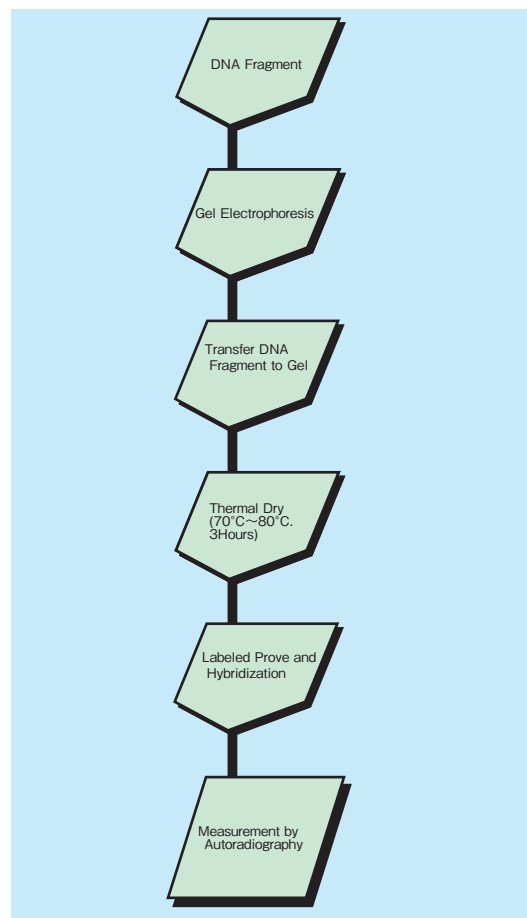

EXAMPLE OF TRANSFER METHOD

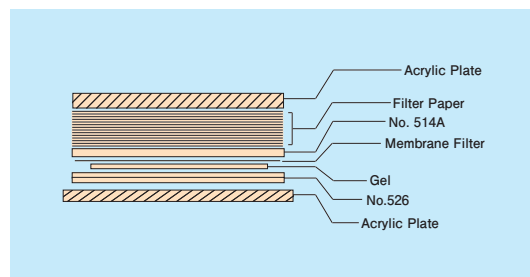

Hydrophobic PTFE

- **Properties:** Thin, highly porous, behaves as an absolute retentive membrane
- **Inert** to most chemically aggressive solvents, strong acids and bases
- **Operating Temperature Range:** -120 ~ 260°C
- **Autoclavable**

APPLICATIONS

- Sterilize gases: traps aqueous aerosols
- Air and gas venting: allows gases to pass freely while blocking aqueous liquids, protect vacuum pumps and critical samples
- Sterilize and clarify strong acids and many other solvents incompatible with other membranes



Hydrophobic PTFE

SPECIFICATIONS: HYDROPHOBIC PTFE MEMBRANE, CODE T

Pore Size (µm)	Bubble Point ^{*1}		Flow Rates ^{*2}		Porosity ^{*3} (%)	Maximum Operating Temperature (°C)	Thickness (µm)
	MPa	psi	Acetone (mL/min/cm ²)	Air (L/min/cm ²)			
0.10	≥0.12	≥17.4	27.0	-	68	260	70
0.20	≥0.091	≥13.2	55.0	-	74	260	80
0.50	≥0.063	≥9.1	100	-	78	260	75
0.80	≥0.039	≥5.7	200	-	76	260	75
1.00	≥0.031	≥4.5	300	-	79	260	75
3.00	≥0.013	≥1.9	750	-	83	260	75

Definitions:

*1. Bubble point is the minimum pressure required to force air through a membrane which has been prewet with isopropylalcohol

*2. Flow rates determined under constant vacuum 0.7 kg/cm² (10 psi)

*3. Porosity refers to the percent open area

ORDERING INFORMATION: HYDROPHOBIC PTFE – NON-STERILE

Plain White discs

Pore Size (µm)	Diameter					
	13 mm	25 mm	47 mm	90 mm	142 mm	293 mm
	Package of 100			Package of 25		Package of 10
0.10	T010A013A	T010A025A	T010A047A	T010A090C	T010A142C	T010A293D
0.20	T020A013A	T020A025A	T020A047A	T020A090C	T020A142C	T020A293D
0.50	T050A013A	T050A025A	T050A047A	T050A090C	T050A142C	T050A293D
0.80	T080A013A	T080A025A	T080A047A	T080A090C	T080A142C	T080A293D
1.00	T100A013A	T100A025A	T100A047A	T100A090C	T100A142C	T100A293D
3.00	T300A013A	T300A025A	T300A047A	T300A090C	T300A142C	T300A293D

Metal Content (ppm)

Al	0.001	K	<0.1
Ca	0.001	Mg	0.005
Cr	0.001	Mn	<0.001
Cu	0.01	Na	<0.05
Fe	<0.001	Ni	0.005

Hydrophobic PTFE with Supported PP Net

- **Properties:** Thin, highly porous, behaves as an absolute retentive membrane
- **Supported:** polypropylene laminated to one side to improve handling
- **Inert** to most chemically aggressive solvents, strong acids and bases
- **Operating Temperature Range:** -35 ~ 130°C
- **Autoclavable**

APPLICATIONS:

- **Sterilize gases:** traps aqueous aerosols
- **Air and gas venting:** allows gases to pass freely while blocking aqueous liquids, protect vacuum pumps and critical samples
- **Sterilize and clarify** strong acids and many other solvents incompatible with other membrane

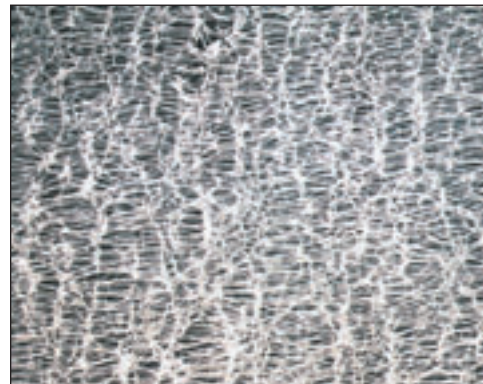

Hydrophobic PTFE

SPECIFICATIONS: HYDROPHOBIC PTFE MEMBRANE, SUPPORTED, CODE J

Pore Size (µm)	Bubble Point ^{*1}		Flow Rates ^{*2}		Porosity ^{*3} (%)	Maximum Operating Temperature (°C)	Water Break Through		Thickness (µm)
	MPa	psi	Acetone (mL/min/cm ²)	Air (L/min/cm ²)			MPa	psi	
0.10	≥0.14	≥20.3	39.1	2.5	72	130	>0.40	>58.0	130
0.20	≥0.097	≥14.1	61.4	4.5	72	130	0.28	40.0	130
0.50	≥0.058	≥8.5	110	7.5	74	130	0.14	20.1	120
1.00	≥0.029	≥4.3	445	17	76	130	0.05	7.0	90

Definitions:

- *1. Bubble point is the minimum pressure required to force air through a membrane which has been prewet with isopropylalcohol
 *2. Flow rates determined under constant vacuum 0.7 kg/cm² (10 psi)
 *3. Porosity refers to the percent open area

ORDERING INFORMATION: HYDROPHOBIC PTFE, SUPPORTED – NON-STERILE

Plain White discs

Pore Size (µm)	Diameter					
	13 mm	25 mm	47 mm	90 mm	142 mm	293 mm
	Package of 100			Package of 25		Package of 10
0.10	J010A013A	J010A025A	J010A047A	J010A090C	J010A142C	J010A293D
0.20	J020A013A	J020A025A	J020A047A	J020A090C	J020A142C	J020A293D
0.50	J050A013A	J050A025A	J050A047A	J050A090C	J050A142C	J050A293D
1.00	J100A013A	J100A025A	J100A047A	J100A090C	J100A142C	J100A293D

Also available in:

- Cartridge format
- Capsule format
- Disposable syringe filter units

Hydrophilic PTFE

- **Characteristics:** Maximum chemical and pH resistance
- **High flow rates** with minimal aqueous extractables (<0.3 wt%)
- **Optically clear** when wet with water
- **Non-supported**
- **Thermostable:** can be used up to 100°C

APPLICATION

- Ideal for HPLC and other mixtures of aqueous and organic solvents

Note: Hydrophilic PTFE membrane filters are not autoclavable.

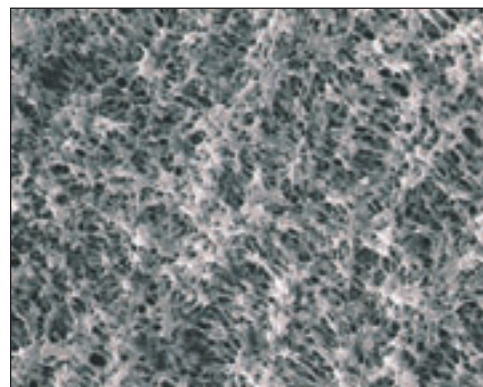

Hydrophilic PTFE

SPECIFICATIONS: HYDROPHILIC PTFE MEMBRANE, CODE H

Pore Size (µm)	Bubble Point ^{*1}		Flow Rates ^{*2}		Porosity ^{*3} (%)	Thickness (µm)	Maximum Operating Temperature (°C)
	MPa	psi	Water (mL/min/cm ²)	Air (L/min/cm ²)			
0.10	≥0.38	≥55.1	14	1.6	71	35	100
0.20	≥0.24	≥34.8	21	2.1	71	35	100
0.50	≥0.14	≥20.3	39	2.9	79	35	100
1.00	≥0.083	≥12.0	73	5.7	83	35	100

Definitions:

- *1. Bubble point is the minimum pressure required to force air through a membrane which has been prewet with water
- *2. Flow rate indicates initial flow rate at 10 psi using a KGS 47 filter holder
Water: using water prefiltered to 0.1 µm pore size
Air: using 25°C air at 10 psi
- *3. Porosity refers to the percent open area

Metal Content (ppm)

Al	15	K	8
Ca	13	Mg	1
Cr	<1	Mn	0.1
Cu	0.5	Na	20
Fe	<10	Ni	0.9

ORDERING INFORMATION: HYDROPHILIC PTFE – NON-STERILE

Plain White discs

Pore Size (µm)	Diameter					
	13 mm	25 mm	47 mm	90 mm	142 mm	293 mm
	package of 100			package of 25		package of 10
0.10	H010A013A	H010A025A	H010A047A	H010A090C	H010A142C	H010A293D
0.20	H020A013A	H020A025A	H020A047A	H020A090C	H020A142C	H020A293D
0.50	H050A013A	H050A025A	H050A047A	H050A090C	H050A142C	H050A293D
1.00	H100A013A	H100A025A	H100A047A	H100A090C	H100A142C	H100A293D

Also available in:

- Cartridge format
- Capsule format
- Disposable syringe filter units

Coated Cellulose Acetate

- **Composition:** Cellulose acetate cast onto a non-woven polyester support
- **Characteristics:** Non-fiber releasing
- **Low protein binding** relative to nitrocellulose
- **Low static charge** matrix with enhanced chemical compatibility to low molecular weight alcohols
- **Autoclavable**

APPLICATION

- Use as a clarifying filter or prefilter

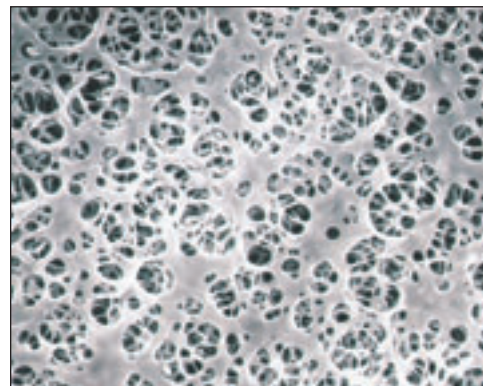

Coated Cellulose Acetate

SPECIFICATIONS: COATED CELLULOSE ACETATE (CMF), CODE Y

Nominal Rating (µm)	Bubble Point* ¹		Flow Rate* ²		% Latex Particle Retention (particle size in µm)							
	MPa	psi	Water (mL/min/cm ²)	Air (L/min/cm ²)	0.48	0.65	0.80	1	2	3	5	10
0.80	≥0.088	≥12.8	100	10	99	99	>99.9	-	-	-	-	-
2.00	≥0.049	≥7.1	290	32	96	99	99	99	>99.9	-	-	-
10.00	≥0.017	≥2.6	750	80	-	-	-	-	98	99.9	99.9	>99.9

Definitions:

*1. Bubble point is the minimum pressure required to force air through a membrane which has been prewet with water.

*2. Flow Rate indicates initial flow rate at 10 psi using a KGS-47 filter holder.

Water: using water prefiltered to 0.1 µm pore size

Air: using 25°C air at 10 psi

ORDERING INFORMATION: COATED CELLULOSE ACETATE – NON-STERILE

Plain White, package of 100 discs

Nominal Rating (µm)	Diameter							
	35 mm	47 mm	76 mm	90 mm	124 mm	142 mm	257 mm	293 mm
0.80	Y008A035A	Y008A047A	Y008A076A	Y008A090A	Y008A124A	Y008A142A	Y008A257A	Y008A293A
2.00	Y020A035A	Y020A047A	Y020A076A	Y020A090A	Y020A124A	Y020A142A	Y020A257A	Y020A293A
10.00	Y100A035A	Y100A047A	Y100A076A	Y100A090A	Y100A124A	Y100A142A	Y100A257A	Y100A293A

Also available in:

- Cartridge format (TCY and TCYE)

Polycarbonate

- **Characteristics:** Low non-specific binding and optically translucent, extremely uniform, cylindrical pores
- **Thin screen-type membranes** minimize entrapment within the filter structure; resulting in surface capture of particles on the membrane
- **Stable:** excellent chemical resistance, good thermal stability, non-hygroscopic and extremely weight stable
- **Autoclavable:** at 121° C, 30 min.

APPLICATIONS

- Epifluorescence microscopy: available in black for this method
- Electron microscopy: smooth surface is ideal for observing captured particles
- Light microscopy: easily transparentized for optical illumination
- Beverage and sterility testing

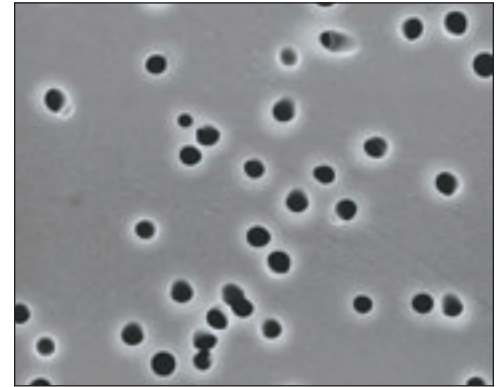

Polycarbonate

SPECIFICATIONS: POLYCARBONATE MEMBRANE, CODE K

Pore Size (μm)	Bubble Point* ¹		Flow Rate		Nominal Thickness (μm)
	MPa	psi	Water* ² (mL/min/cm ²)	Air* ³ (L/min/cm ²)	
0.10	≥ 0.22	≥ 30	5	2	6
0.20	≥ 0.13	≥ 20	15	4	10
0.40	≥ 0.082	≥ 12	50	10	10
0.80	≥ 0.048	≥ 7	130	20	9
8.00	≥ 0.0048	≥ 0.7	1,000	40	7

Maximum operating temperature = 140°C

Definitions:

*1. Bubble point is the minimum pressure required to force air through a membrane which has been prewet with isopropylalcohol

*2. Initial flow rates using prefiltered water at 10 psid (0.7 kg/cm²)

*3. Initial flow rates using prefiltered air at 10 psid (0.7 kg/cm²)

ORDERING INFORMATION: POLYCARBONATE – NON-STERILE

Plain White, package of 100 discs

Pore Size (μm)	Diameter		
	13 mm	25 mm	47 mm
0.10	K010A013A	K010A025A	K010A047A
0.20	K020A013A	K020A025A	K020A047A
0.40	K040A013A	K040A025A	K040A047A
0.80	K080A013A	K080A025A	K080A047A
8.00	K800A013A	K800A025A	K800A047A

Plain Black, package of 100 discs

Pore Size (μm)	Diameter	
	25 mm	47 mm
0.20	K020N025A	K020N047A
0.40	K040N025A	K040N047A

Prefilters for Membrane Filters

The term “prefilter” refers to any type of filter that precedes the final barrier. This type of filter is often prepared from depth-type media, a random matrix of glass, cellulose, quartz or PTFE fibers. This fiber matrix may or may not include binder to maintain integrity. Because these filters trap particles within the matrix, they have a very high particle loading capacity. However, this type of filter does not have a clearly defined pore rating, only a nominal designation.

Not all depth-type filters are used as prefilters: these can be used in a wide variety of applications, such as water and air pollution analysis, liquid clarification, and cell harvesting.

Generally, a prefilter should be slightly smaller than the membrane filter it is preceding, but full sized prefilters are recommended if used alone.

Filter Holder Model	Recommended Prefilter Diameter (mm)	
	used upstream of membrane	used alone
Vacuum Type:		
KG-25, KGS-25	16	25
KG-47, KGS-47, KSF-47, KGS-47-TF	35	47
KG-90, KGS-90	70	90
Pressure Type:		
KS-13	8	13
KS-25, KS-25F, PP-25	21	25
KS-47, KST-47, KS-47F	35	47
PP-47, PFA-47	42	47
LS-25	25	25
LS-47	47	47
LS-47-HP	38	47

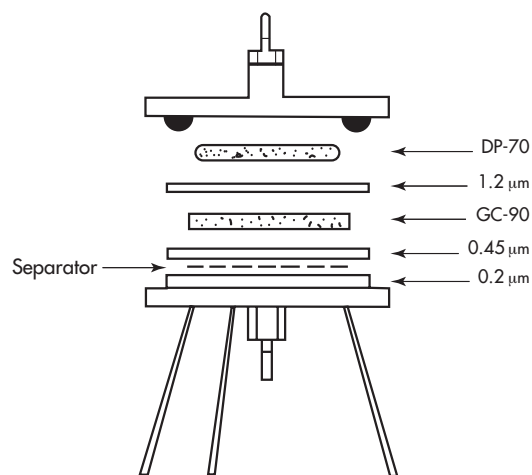

A typical serial stack incorporating Prefilters, Membranes and Polyester Mesh Separators.

Polyester Mesh Separators

- **Prevent pore blinding** by placing a polyester mesh separator between two membranes in series
- **Improve performance:** Increase liquid flow rate and throughput
- **Mesh Size:** 28 mesh

Note: Order same size recommended for prefilters.

ORDERING INFORMATION: POLYESTER MESH SEPARATORS

Diameter (mm)	35	76	124	257
Catalog No.	48141035	48141076	48141124	48141257
Quantity per package	50	25	25	25

Disposable Syringe Filter Units – DISMIC/LABODISC

- **Minimum sample hold-up:** Unit housings are specifically designed to maximize sample recovery
- **High purity:** Non-pigmented housing and integral filter sealing assure that filtrates will not be adulterated due to pigment, dye, or adhesives leaching into the filtrate
- **Convenient:** Each unit is clearly marked with an identifying code to denote pore size, membrane material and housing polymer
- **Sterile:** Units can be purchased pre-sterilized and individually packaged, or non-sterile in bulk pack
- All polypropylene can be autoclaved
Acrylic can not be autoclaved



3, 13, 25, and 50 mm disposable syringe filter units.

SPECIFICATIONS

Diameter		DISMIC				LABODISC
		3 mm	13 mm	25 mm	50 mm	
Housing material	-	PP	PP	PP	Acrylic	PP
Filtration Area	cm ²	0.06	0.9	4.0	4.0	19.6
Hold-up Volume	mL	≤0.01	≤0.03	≤0.1	≤0.1	≤3.0
Suggested capacity per filter unit	mL	<2 mL	<10 mL	<100 mL	<100 mL	>100 mL
Pressure limit	MPa	0.51	0.51*	0.51*	0.51	0.34
	psi	74	74*	74*	74	49
Maximum Operating Temperature	°C	60	60	60	45	60
	°F	140	140	140	113	140
Connections	-	Inlet: female luer-lock outlet: male luer slip				7–13.5 mm hose barb with male luer slip

*13HP, 25HP; Pressure Limit = 0.39 MPa (57 psi)

Mixed Cellulose Esters (MCE)

- Properties: A hydrophilic membrane
- Higher protein binding than cellulose acetate for most proteins
- High porosity provides a high flow rate

Cellulose Acetate (Acetate)

- Standard: A commonly used hydrophilic membrane
- Low protein binding, suitable for aqueous protein solutions
- Nitrate-free, suitable for groundwater filtration
- Housing material: polypropylene (3, 13, 50 mm) or styreneacrylonitrile (25 mm)

PTFE, hydrophilic

- Versatile: Good chemical resistance
- Compatible with many solvent mixtures used in HPLC, e.g. Acetonitrile/Water

PTFE, hydrophobic

- Application: use as vent

For ordering information, see page 16.

Diameter	Membrane material	Housing material	Pore size	Filter surface	Sterile
25 ··· 25mm	A ··· Mixed Cellulose Esters(MCE)	S ··· Acrylic	020 ··· 0.20µm	A ··· White Plane	S ··· Pre-Sterilized
13 ··· 13mm	C ··· Cellulose Acetate	P ··· Polypropylene	045 ··· 0.45µm		N ··· Non-Sterile
03 ··· 3mm	H ··· PTFE, hydrophilic		050 ··· 0.50µm		
	J ··· PTFE, hydrophobic		080 ··· 0.80µm		

ORDERING INFORMATION DISPOSABLE SYRINGE FILTER UNITS

DISMIC

Diam.	Membrane material	Pore size (µm)	Housing material	Quantity per package	Non-Sterile	Sterile
3	Cellulose Acetate	0.20	Polypropylene	100	03CP020AN	03CP020AS
		0.45	Polypropylene	100	03CP045AN	03CP045AS
	PTFE, Hydrophobic	0.50	Polypropylene	100	03JP050AN	-

3mm



13	Cellulose Acetate	0.20	Polypropylene	100	13CP020AN	13CP020AS
		0.45	Polypropylene	100	13CP045AN	13CP045AS
	PTFE, Hydrophilic	0.20	Polypropylene	100	13HP020AN	-
		0.45	Polypropylene	100	13HP045AN	-
	PTFE, Hydrophobic	0.20	Polypropylene	100	13JP020AN	-
		0.50	Polypropylene	100	13JP050AN	-

13mm



25	MCE	0.20	Acrylic	50	25AS020AN	25AS020AS
		0.45	Acrylic	50	25AS045AN	25AS045AS
	Cellulose Acetate	0.20	Acrylic	50	25CS020AN	25CS020AS
		0.45	Acrylic	50	25CS045AN	25CS045AS
		0.80	Acrylic	50	25CS080AN	25CS080AS
	PTFE, Hydrophilic	0.20	Polypropylene	100	25HP020AN	-
		0.45	Polypropylene	100	25HP045AN	-
	PTFE, Hydrophobic	0.20	Polypropylene	50	25JP020AN	-
		0.50	Polypropylene	50	25JP050AN	-

25mm Acrylic



25mm PP



LABODISC

50	Cellulose Acetate	0.20	Polypropylene	10	50CP020AN	50CP020AS
		0.45	Polypropylene	10	50CP045AN	50CP045AS
	PTFE, Hydrophobic	0.20	Polypropylene	10	50JP020AN	-
		0.50	Polypropylene	10	50JP050AN	-

50mm

